



Standard Test Method for Peel Strength (“T” Method) of Hook and Loop Touch Fasteners¹

This standard is issued under the fixed designation D5170; the number immediately following the designation indicates the year of original adoption or, in the case of revision, the year of last revision. A number in parentheses indicates the year of last reapproval. A superscript epsilon (ϵ) indicates an editorial change since the last revision or reapproval.

1. Scope

1.1 This test method covers the measurement of the peel strength of hook and loop touch fasteners using a recording constant-rate-of-extension tensile testing machine (CRE).

1.2 The values stated in inch-pound units are to be regarded as standard. The values given in parentheses are mathematical conversions to SI units that are provided for information only and are not considered standard.

1.3 *This standard does not purport to address all of the safety problems, if any, associated with its use. It is the responsibility of the user of this standard to establish appropriate safety and health practices and determine the applicability of regulatory limitations prior to use.*

2. Referenced Documents

2.1 *ASTM Standards:*²

[D618 Practice for Conditioning Plastics for Testing](#)

3. Significance and Use

3.1 This test method gives a measure of a key property of hook and loop touch fasteners which is of interest to users of such devices. This is a means of determining the resistance to separation when forces are applied normal to the line of separation of the fastener.

3.2 The force registered in a peel test is irregular, and as a consequence, empirical methods have had to be developed to obtain usable values related to peel strength. In spite of the empirical nature of the reported values, it is believed they reflect comparative performance of similar touch fasteners tested and measured in the same way.

3.3 Two optional methods of calculation are provided: integrator average and average of five highest peaks. These test

methods are not equivalent. Generally, the integrator average will be lower than the average of the five highest peaks.

3.4 The highest peaks which reflect the force required to separate a hook and loop closure bear no simple relationship to the average force (integrator average). The average of the five highest peaks better reflect performance but the integrator results may be used to characterize a closure and for quality control purposes. The integrator average is relatively easy to calculate given the proper equipment.

3.5 In the case of a dispute arising from differences in reported test results when using this test method for acceptance testing of commercial shipments, the purchaser and the supplier should conduct comparative tests to determine if there is a statistical bias between their laboratories. Competent statistical assistance is recommended for the investigation of bias. As a minimum, the two parties should take a group of test specimens which are as homogenous as possible and which are from a lot of hook and loop of the type in question. The test specimens should then be randomly assigned in equal numbers to each laboratory for testing. The average results from the two laboratories should be compared using Student’s t-test and an acceptable probability level chosen by the two parties before the testing began. If a bias is found, either its cause must be found and corrected or the purchaser and the supplier must agree to interpret future test results in the light of the known bias.

4. Apparatus

4.1 *Roller*—consisting of a smooth steel surface, approximately 4¾ in. (121 mm) in diameter, 2¼ in. (57 mm) wide, and equipped with a handle, length 4⅞ in. (105 mm), for propelling the roller back and forth without adding additional weight to the specimen being rolled (See [Fig. 1](#)). The weight of the roller (including the handle) is 11 ± ¼ lbs. (4994 g ± 114 g).

4.2 *Testing Machine*—A constant rate of extension (CRE) tensile tester shall be used. The tester shall have two clamps with centers in the same plane, parallel to the direction of the motion of the stressing clamp, and so aligned that they will hold the specimen ends wholly in the same plane; a means of moving the stressing clamp at a uniform rate of 12.0 ± 0.5

¹ This test method is under the jurisdiction of ASTM Committee D13 on Textiles and is the direct responsibility of Subcommittee D13.54 on Subassemblies.

Current edition approved Feb. 1, 2015. Published April 2015. Originally approved in 1991. Last previous edition approved in 2010 as D5170 - 98(2010). DOI: 10.1520/D5170-98R15.

² For referenced ASTM standards, visit the ASTM website, www.astm.org, or contact ASTM Customer Service at service@astm.org. For *Annual Book of ASTM Standards* volume information, refer to the standard’s Document Summary page on the ASTM website.

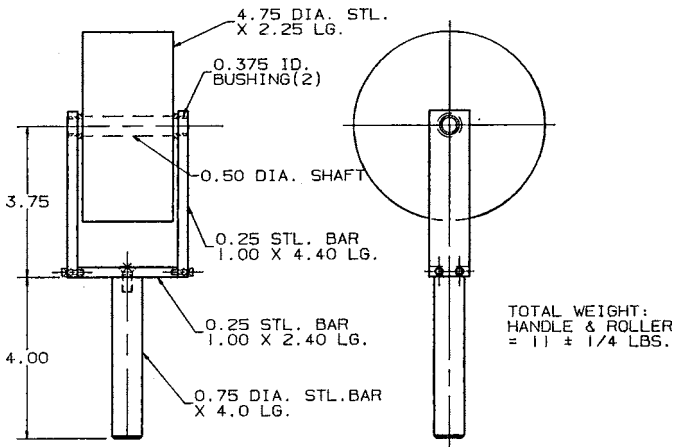

FIG. 1 Roller for Making Closure of Hook and Loop Touch Fasteners Prior to Testing

6.1.3 Select a sample consisting of four contiguous specimens as described in 8.1.2 and mark them with the appropriate identification (roll number, lot number, date, and so forth). There are four possible direction configurations of closure as shown in Fig. 2. The four specimens of hook and loop selected will be used to characterize the peel strength of each of the configurations.

7. Conditioning

7.1 Condition the specimens in an atmosphere for testing of $23 \pm 2^\circ\text{C}$ ($73.4^\circ\text{F} \pm 3.6^\circ\text{F}$) and $50 \pm 5\%$ relative humidity, as described in Practice D618, for a period of 24 h or until the specimens reach moisture equilibrium. Lay specimens flat with the functional side up so that the conditioning atmosphere has free access to them.

8. Procedure

8.1 An initial closure is made and separated to raise the loops that might have been compressed in packaging.

in./min (305 ± 13 mm/min), an autographic device for recording the load; and provided with an integrator if the integrator average is to be used.

4.2.1 The instrument shall be calibrated to an accuracy of 1.0 % of the full scale and the scale range used for the test shall be such that the main test falls within 20 to 80 % of full range.

5. Sampling

5.1 Select the test samples so as to be as representative of the unit (a shipment, a lot, and so forth) as possible.

5.2 Lot—A lot shall consist of all the material of the same type, color and width, made at the same time from the same materials in no more than a two week period. It shall be expressed in linear units of 10 000 yards (9144 m).

5.3 Sample Rolls—One roll shall be randomly selected from each linear unit 10 000 yards (9144 m). If the lot does not contain five units, additional rolls shall be selected from the lot to give a sample size of five rolls.

5.4 For specification purposes, the material under test must be mated with material supplied by the manufacturer of the material being tested.

6. Specimen Preparation

6.1 Hook and loop material for this test shall be in the width as supplied, not to exceed 1 in. (25.4 mm) in width. For materials greater than 1 in. (25.4 mm), a 1 in. (25.4 mm) specimen shall be slit from the center of the sample. If material less than 1 in. (25.4 mm) wide is tested, test results will not be directly proportional to those obtained with the 1 in. (25.4 mm) wide material.

6.1.1 Remove the outer layer of each roll before selecting the required number of strips, hook and loop, 8 in. \pm 1/4 in. (203 ± 6 mm) long.

6.1.2 Each specimen is marked with an arrow (\uparrow) pointing in the direction that the specimen is unwound from the roll. This arrow is marked on the specimen on the leading end as it is unwound from the roll. The arrow (\uparrow) indicates the direction of the hooks and loops of the specimens.

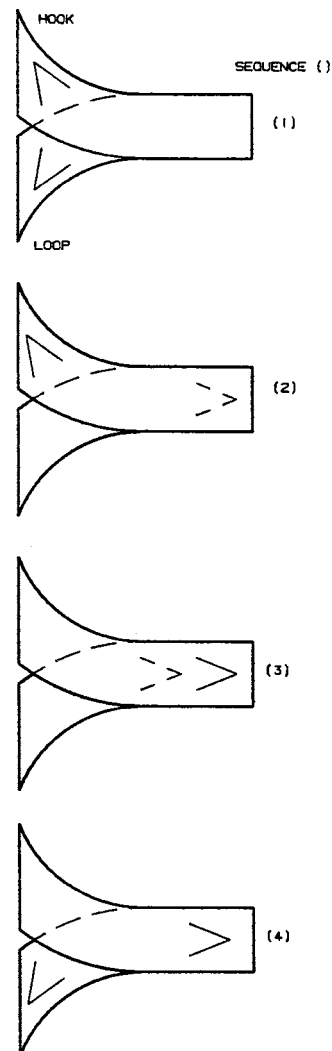

FIG. 2 Test Configurations for "T" Peel Strength of Hook and Loop Fasteners (Not to Scale)